



“Here there be dragons!”
— Classical phrase used by ancient
Roman and medieval cartographers.

The quotation above is particularly relevant to this project. It is a phrase used to denote an unexplored territory, and refers to the Roman medieval practice of putting sea serpents and other mythological creatures in blank areas of maps.

We have already explored several types of long range locator (LRL) in the previous chapter¹, but the pistol detector (PD) is a curious beast that warrants a chapter all to itself. Firstly, the term “pistol detector” does not refer to an ability to detect pistols, but instead describes the mechanical construction and the way it is held. Traditional metal detectors have a search coil attached to a long stem that is swept back and forth across the surface of the ground. In contrast the PD is held at chest height, some considerable distance above the ground, in the manner of a pistol; see Figure 1 for a typical example. The search coil on the device points forwards in a horizontal fashion, and not downwards. The general idea behind this device is to detect any anomalies, which may be present in the background electromagnetic noise, which might be associated with longtime buried treasure.

It is easy to dismiss LRLs as working by self-deception, because the final recovery is nearly always performed using a conventional metal detector. However, in the case of the PD, the device incorporates a TR-type detector that can be used to pinpoint the target. Therefore it is difficult to use the same argument as for the other LRLs, because there is no doubt, in the case of a recovered target, that the PD was involved. The important question is whether this device has any credibility as an LRL, or is this just another case of wishful thinking? Note that many LRL proponents claim the PD is really a medium range locator (MRL) with detecting

distances measured in meters rather than kilometers.

As usual, many theories abound purporting to explain the abilities of the PD, including the usual ionic nonsense. In general though, most proponents agree that the PD is detecting some “phenomenon” surrounding longtime buried objects (in particular, gold and silver) but they cannot explain what it is. The idea of this “phenomenon” is a useful argument in the PD supporter’s toolbox, when experimenters fail to obtain any long (or medium) range detection in the laboratory. It appears the extra range can only be obtained in the field, and in the presence of objects buried for several years, during which time the “phenomenon” is said to build up in strength. Another excuse, often presented, is that conventional metal detectors destroy the “phenomenon,” and it takes a number of days before it can return to full strength. The general idea behind the PD is to search for an anomaly in the background noise, and to follow this “signal line” to the target. Despite the claim that a PD can only be set up correctly in the field, there are a number of tests that can apparently be performed in the laboratory. One such test involves shorting out a 1.5V battery with a length of wire from several meters away, and checking that it elicits an audio response from the PD. Likewise, the detection of a TV (with a CRT) from 6 meters is touted as a good indication. There is one other lesser known test available that we will describe later in this chapter.

The purpose of the project presented here is to design and build an experimental PD based on information available from the public domain. There are very few detectors of this type for sale in the open market, as the method of construction is relatively complex and fairly difficult to calibrate, given the general lack of information, and there is no accepted scientific theory to back up the claims made for this device.

We are aware of one particular prototype that has been back-engineered and cloned by several amateur experimenters, and there are even videos on the internet of this device in operation. Throughout this chapter we will refer to this prototype as the *original PD*. As far as we can ascertain, the clones that have been constructed have either failed to function properly, or have fallen short of the claims for the original device. Even the videos of the *original PD*, showing it in operation, are not totally convincing, and could easily be explained away as wishful thinking. The *original PD* consists of a TR detector circuit, which is used for pinpointing and final recovery, and a separate receiver circuit that uses a coil wound on a ferrite rod. Investigations have shown that the TR circuit is an exact copy of a Heathkit GD348, which

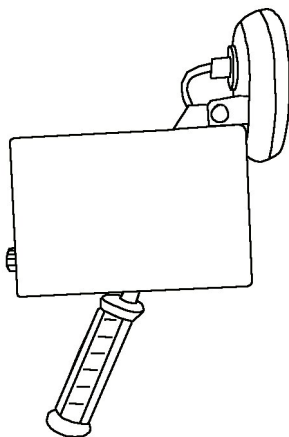

Fig. 1: Typical example of a Pistol Detector

1. This article is a reprint of *Inside the Metal Detector*, Chapter 14.

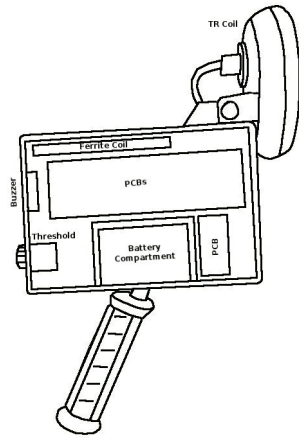

Fig. 2: Inside the Pistol Detector

is a design originating from the 1970s. At this time it is unclear as to whether the ferrite receiver is intended to be used in conjunction with or separate from the TR circuit, due to some confusion concerning the wiring of the selector switch. Of course, anyone with an oscilloscope could find the answer in about 5 minutes, but the *original PD* is considered so precious that this may remain one of its secrets. Even PD proponents are in disagreement over this aspect of the design. In our own PD the intention is to provide both options for maximum flexibility, as the main purpose of the project is to act as an experimental platform in this unexplored territory.

One important point to note is the size of the search coil mounted on the front of the PD. This has a very small diameter of less than 4", and the *original PD* used a search coil housing from a Garrett Groundhog, which again was a detector from the 1970s. This probably puts a date on the construction of this device, and begs the question as to why these PDs are virtually unknown in the metal detecting world today? Perhaps it is such a closely guarded secret that other detector manufacturers are kept in the dark, or simply they do not work as claimed.

The attraction of such a device is clear. It is small in size, conveniently carried out of sight in a rucksack, and can be used to discretely detect treasure from a distance. There is a strong incentive for certain people to believe the claims made for the PD, and a willingness to pay a premium for this capability.

It has been speculated that the PD is simply a miniature version of a 2-box detector, as the TX coil points forward. However, neither the RX coil in the search head nor the ferrite coil point downwards. In this case the 2-box idea must certainly be incorrect.

The only way to settle the controversy surrounding the PD is to build one. Although there is little point in creating yet another clone of the *original PD*, as this has already been done by others, and the results were at best inconclusive. Since the TR section of the design is fairly straightforward, let's start with the ferrite receiver.

Ferrite Receiver

From the information available we know that the coil on the ferrite is tuned to the same frequency as the transmitter, which implies that these two circuits are intended to work together. But, as stated earlier, due to some confusion over the internal wiring of the *original PD*, the intention is to provide both passive and active modes in our design. It is claimed by certain LRL proponents that a frequency of between 60-70 kHz is ideal for long range gold detection. Consequently we have designed our PD to operate at 65 kHz. Note the Heathkit GD348 operated at 100 kHz, but it is known that the *original PD* did not use this frequency. The ferrite rod used in this project was 8 cm long and 1 cm in diameter, with a yellow marking on one end. A small plastic former from a ferrite core was used to support the coil, which consisted of 100 turns of 0.56 mm thick enamelled wire, resulting in an inductance of 870 μ H. The coil was positioned in the center of the ferrite rod, but could be adjusted either way, if desired, to alter the inductance.

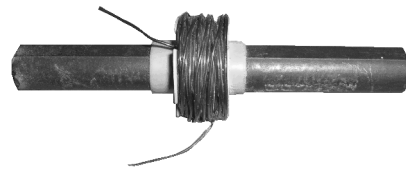

Fig. 3: Ferrite Coil

The receiver circuit consists of a 2-stage pre-amp operating from a single-ended power supply. The reason for this is simply to remove the complication of a dual supply, but to operate in this mode it is necessary to provide a phantom ground. Initially this was created using a simple potential divider, but later in the project it was discovered that unwanted oscillations were occurring due to positive feedback through the power supply. Consequently a third dedicated opamp was used to generate the phantom ground. Stage one of the pre-amp uses a differential configuration with a gain of 50. The output is AC coupled to the second stage, again with a gain of 50. C3 and R3 provide a break frequency of 241 Hz, and the upper cutoff frequency is limited by the gain bandwidth of the opamp to about 80 kHz. C1

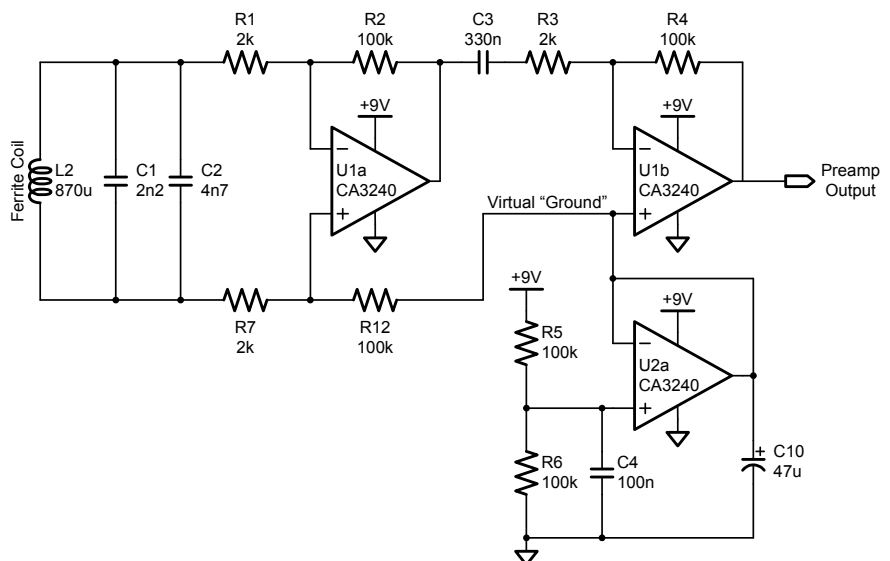

Fig. 4: Pre-amp with single-ended supply

and C2 are used to tune the ferrite coil to approximately 65 kHz.

Initial tests appeared to indicate the receiver was directional, tending to indicate a strong null when pointing north. After further investigation, with an oscilloscope connected to the pre-amp output, it was discovered that a 20 kHz signal was being detected to the east. This was eventually traced to an inductive electric toothbrush charger which had been left connected in an adjacent room. After disconnecting the charger the noise level dropped considerably, and the north direction null was no longer detected.

TX Circuit

A separate forced oscillator transmit circuit, running at 65 kHz, was built to allow some preliminary testing, and used to drive a coil of 80 mm diameter (75 turns of 0.56 mm thick enamelled wire) with no electrostatic shielding. Even at a distance of 3 meters the pre-amp output was 400 mV peak-to-peak. The TX signal is not a perfect sine wave, but this is unimportant. In fact, the Heathkit GD348 produces a series of underdamped pulses, and it is known that many different types of TX circuits are used by LRL experimenters. To increase flexibility during experimentation, R21 (10K) could be replaced with a 10K preset in series with a 4K7 resistor, to allow the TX circuit to be tuned into resonance with the RX coil. The TX frequency can be calculated as follows:

$$f = \frac{1.46}{(RA + 2RB)C} = 69.5\text{kHz} \quad \text{Eq 1}$$

The actual frequency was measured in practice to be 65 kHz. No attempt was made to achieve resonance, so this may be an area worthy of further investigation.

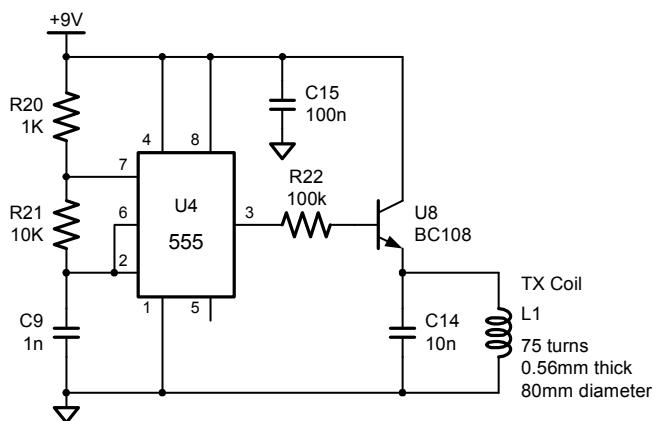

Fig. 5: Transmit Oscillator

The internal layout of the *original PD* implies the existence of a null point at the position of the ferrite, otherwise the pre-amp would be overloaded by the TX signal, but experiments have shown no such null point exists at that location. Interestingly not many people are aware that there is a “null line” which projects away from the edge of the coil at a 45 degree angle. Placing a ferrite coil anywhere along this line will produce a null. In fact, the line projects away from the TX coil all the way round the circumference, both behind and in front, forming two “null cones.” The position of the null is quite easy to find, and with careful adjustment can provide some good sensitivity to non-ferrous targets while at the same time rejecting ferrous items. So the impor-

tant question here is why is the ferrite coil positioned away from the “null line” in the *original PD*?

There are several possible answers:

1. The ferrite coil is only used in passive mode, with the transmitter disabled. In which case a null point is not required.
2. The omega coil configuration, used by the Heathkit GD348 circuit, has a different electromagnetic field pattern that bends the “null line” away from its usual position.
3. A different method is being used to null the ferrite coil.

Let's look at each possibility in turn:

1. Our own experimental PD will have active and passive modes selectable from the front panel, allowing both modes of operation to be tested.
2. The omega coil does appear to distort the electromagnetic field, but the distortion is insufficient to bend the “null line” into the required position.
3. Close examination of the ferrite coil of the *original PD* reveals there are in fact two ferrite rods (or one rod cut into two parts) connected together, but leaving a small gap. There are also two coils wound onto the ferrites in anti-phase. The conclusion is that the coil closest to the TX coil is used for nulling. This coil is not driven directly by the TX circuit, but relies on the current induced in the first ferrite by the TX coil. Nulling is achieved by adjusting the gap between the two ferrites. This indicates there is a strong possibility that the *original PD* must operate in active mode, otherwise there would be no requirement for the second nulling coil.

The discovery of a nulling coil shows the constructors of the *original PD* were either unaware of the already existing “null line,” or they deliberately placed the ferrite coil higher up to reduce the size of the PD enclosure.

Experiments have shown it is possible to place the ferrite coil on the “null line” using an enclosure similar to the original, but its consequent proximity to the PCB and associated wiring causes tremendous instability. Therefore an alternative solution was found by placing the ferrite coil on the “null line” above the TX coil. This provides the advantages of ease of nulling (the two ferrite solution is known to be difficult to implement) and improved stability, but with the slight disadvantage of increased enclosure size.

It would also be reasonable to question why a ferrite coil is used for the receiver when an air coil could possibly perform the same function? It is highly likely that the answer has its roots in the old miner's tale of a man who was able to

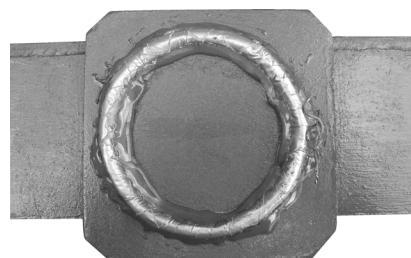

Fig. 6: Transmit Coil

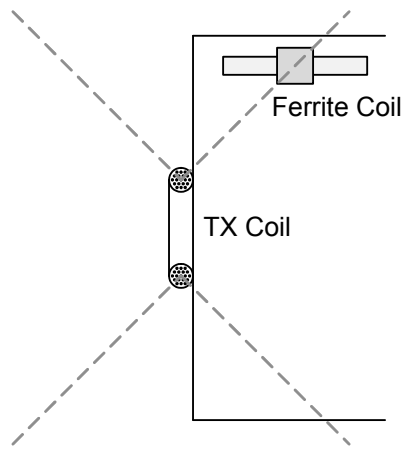

Fig. 7: “Null lines” around TX coil

detect gold using only an AM radio tuned off-station. Whenever he detected a null in the audio hiss it was an indication that he was close to an ore deposit. This is the basic idea behind the passive LRLs which contain ferrite rods. So somewhere along the way, the use of a ferrite coil has become synonymous with long range detection. You may also question why the ferrite rod is not positioned broadside, rather than pointing end-on, to the front of the unit? Surely AM radios are always positioned so the ferrite antenna is broadside to the radio transmitter?

First let's look at the basics of a ferrite rod antenna. Ferrite is an iron-based magnetic material with a high permeability. This causes the magnetic component of the transmitted signal to be concentrated in the rod, which has the advantage of making it directive. This means that reception is highest when the magnetic lines of force are in line with the long axis of the antenna. Conversely the antenna receives minimum signal when it is end on to the radio transmitter. So doesn't this mean the ferrite rod in the PD is positioned incorrectly, and really needs to be rotated by 90 degrees?

Not at all!

Remember that a radio transmitter uses a long vertical pole as an antenna, and this produces a magnetic field pattern of concentric rings that radiate outwards horizontally in all directions. For the ferrite antenna to concentrate the maximum lines of force it must be positioned horizontally and broadside to the transmitter. In the case of the PD the magnetic field pattern is very different. For the ferrite antenna to receive maximum signal it must be positioned end on to the TX coil. The simplest way to imagine what's happening is to picture the receive coil on its own without the ferrite rod. This is exactly the same situation that occurs in a concentric coil. In fact, it then becomes obvious the two ferrite solution in the *original PD* is a direct extrapolation of the concentric coil concept with its TX, RX and nulling coil.

The Sky and Compass Effects

Several PD builders have discovered their clones of the *original PD* will beep when pointed to the sky. That is, anywhere above the horizon. There is also a compass effect whereby the PD is aligned to the north / south direction, which also causes a beep. Some experimenters (but not all) believe the *original PD* designer discovered that an unshielded coil is able to detect the “phenomenon,” but both the sky and compass effects tend to mask the signal. The

conclusion is that the purpose of the ferrite coil is to eliminate both of these effects, thus allowing the signal to be detected more easily. To achieve this situation the ferrite and TR coils must be set to a critical balance.

Interestingly you can experience the sky effect with both a standard Heathkit GD348 detector and a Micronta 4001. Both of these detectors are of the TR variety that use an omega configuration with unshielded coils. However, a C.SCOPE 220 (which is also a TR) does not exhibit the sky effect at all. This could be due to the C.SCOPE search coil having a DD configuration. But being a more modern design, the coils are also likely to be shielded. Unfortunately we were unable to dismantle the search head to confirm this assumption.

According to other LRL experimenters, the ferrite coil is used to cancel the sky effect produced by the omega coil. But for this to be true, the ferrite coil must also be detecting this effect, otherwise it would not be possible to produce a cancellation signal. Here is the paradox — from our own experiments it is clear that the ferrite coil does not exhibit either the sky or compass effects. In other words, how can any cancellation occur when neither of these effects are detected by the ferrite coil? The obvious conclusion is that the sky detection problem, in particular, is an unwanted side effect of the unshielded RX coil, and the even more obvious solution is to use only the TX and ferrite coil without the RX. You might then ask, why does the *original PD* retain the RX coil? It appears the LRL proponents are searching for a complicated solution to explain their inability to clone the *original PD*, when in fact the answer is quite simple. The TR detector is for short range pinpointing, and is only there to reinforce the user's belief that the PD is capable of medium and long range detection, because the final recovery is made using the same device. In addition, the internet videos of the *original PD* show the compass effect to still be present. So what happened to the so-called cancellation? The intended role and interactions between the TR circuit and the ferrite coil are extremely unclear, even amongst those with firsthand experience of the *original PD*. Discussions involving this topic will no doubt rattle on for several years to come, until the prototype is accidentally lost or destroyed, thereby creating yet another LRL myth.

Detecting the Anomaly

One common feature of PD-type LRLs is the use of a pulse extender. Its purpose is to allow any short duration signal, that appears above the background noise, to become audible to the operator.

First it is necessary to compare the output from the pre-amp with a fixed threshold. In this project we have used an identical circuit to that used to generate the phantom ground. The duplication is required to prevent positive feedback occurring that would result in unwanted oscillation. Two separate comparators are used. One is used to drive the yellow LED, which indicates the strength of the input signal. This facility is somewhat limited in practice, but it was retained in order to make use of the second comparator in the LM393. The second comparator drives the pulse extender that consists of a 555 timer configured as a monostable which provides a pulse of 80 ms. The pulse extender in the *original PD* provided a pulse width of 363 ms, but the

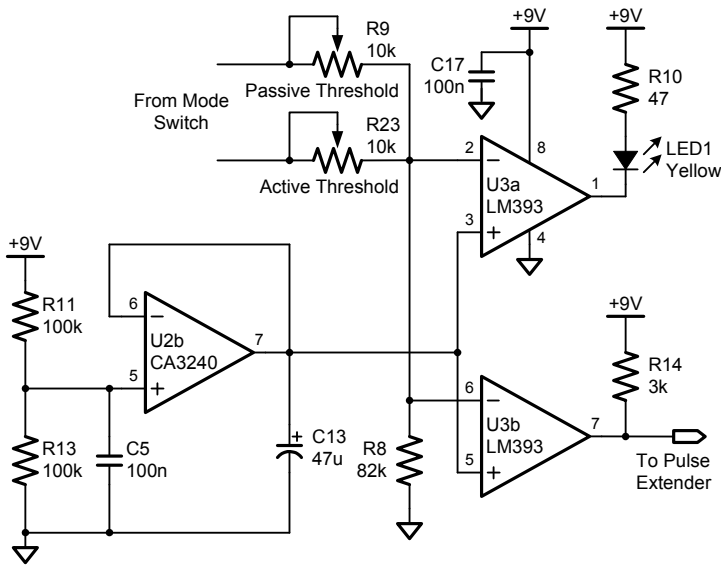

Fig. 8: Comparator circuit

shorter 80 ms pulse was found to be more effective at determining the direction of the received signal. The output of the pulse extender drives both a red LED and a piezoelectric buzzer.

After much effort was expended in trying to eliminate the buzzer, and replace it with a more standard audio oscillator and speaker combination, it was found that the speaker caused a lot of interference, making this approach useless as an alternative solution. Clearly this is the reason why the buzzer is the preferred approach by LRL experimenters. Because the buzzer can be somewhat annoying, and may attract undesired attention while using the device, an on-off switch was incorporated to disable the audio output. For the occasions where an audio output is not desired, and the ambient light is too bright to see the LEDs, a meter was added to provide an extra visual indication. The most effective result was obtained by putting the meter on the same output as the buzzer. Originally the meter was connected to the same output as the yellow LED, but the response was very poor. In the final implementation the diode D1 limits the voltage across the meter and R24, which in turn limits the current through the meter to the 250 μ A required for full scale deflection (FSD) and prevents the meter needle from hitting the end stop. For added flexibility C18 can be switched in or out of circuit to provide either a slow or fast meter response.

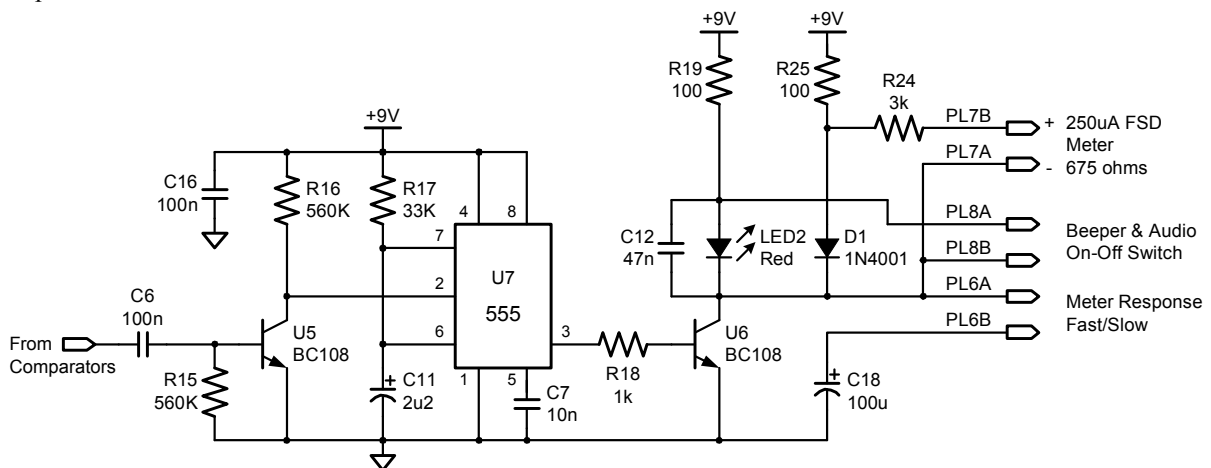

Fig. 9: Pulse extender and audio output

The Front Panel Controls

- On-off switch
Simply turns the PD on or off.
- Active and passive thresholds
Since the PD is capable of being used as a passive receiver or an active TR, there are two separate 10-turn pots for the two modes.
- Active / passive switch
Allows operation in passive mode (receive only, no transmitter) or active mode (transmit and receive).
- Audio on-off
Turns the buzzer on or off.
- Meter response
Controls how the meter responds to the input signal.

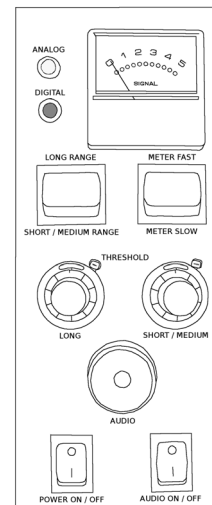

Fig. 10: Control panel layout

TR Mode of Operation

Although the *original PD* could also be used as a mini version of the Heathkit GD348 for pinpointing purposes, it was found that our own PD could be used in the same way without the complication of adding another receive coil and associated circuitry. Having tested a GD348 firsthand, it was easy to confirm the target response of the Heathkit is relatively poor. Considering the *original PD* uses exactly the same circuit, but with a much smaller search coil (less than

4" as opposed to the original 10" of the Heathkit) it was clear that the PD's short range detecting ability would be even less effective. Even with the built-in TR circuit the *original PD* often required a conventional metal detector to pinpoint and recover the target. The response at short range of our own PD was found to be at least the same, if not better, than the original, but using the ferrite receiver for short range as well as medium and long range detection. Also, as described earlier, an unshielded RX coil produces the unwanted sky effect, and in some cases a compass effect as well.

Nulling the Ferrite Coil

As mentioned earlier it is critical to correctly position the ferrite coil to achieve maximum sensitivity and to provide ferrous rejection. It is important that the enclosure is constructed of wood. Definitely do not use metal, and the use of a plastic box is not recommended by the LRL experimenters who believe the "phenomenon" to be ionic-based. If you construct the enclosure according to the measurements shown in the diagram, the nulling of the ferrite coil should be reasonably straightforward.

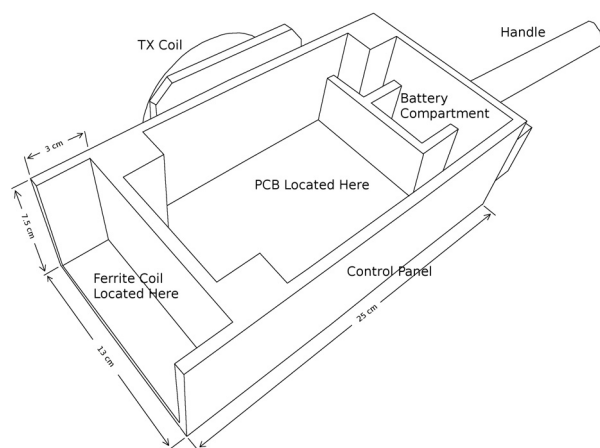

Fig. 11: Inside the TOTeM PD

The prototype was constructed using 5 mm thick medium density fibreboard (MDF) but plywood would also be suitable. First attach the ferrite coil to a small piece of MDF using hot glue, and place it in the middle of the upper compartment as shown in the photos. Make sure the passive/active switch is set to "active", and adjust the active threshold pot until an audible sound is heard from the buzzer. Carefully adjust the position of the ferrite coil until the sound stops. Try to locate the coil in the center of the null. Then readjust the position of the active threshold, and repeat the procedure until no more improvement can be obtained. At this point you should be able to detect non-ferrous targets placed near the TX coil, while rejecting ferrous targets. Previously we discussed shorting a 1.5V battery using a length of wire in order to test the PD's ability to detect a spark. This should be detectable from at least 3 meters. An additional test, particularly for the passive mode, is to move a magnet near the ferrite, which should produce a clear audio response. If you do not have a magnet available, then a magnetized screwdriver can be used as a suitable substitute. The audio response is caused by discontinuous "jumps" due to domain wall movement in the ferrite material as the domain walls become pinned and released from microstructural obstacles. Each abrupt "jump" produces a brief burst of mag-

netic noise, known as Magnetic Barkhausen Noise (MBN). Once you are satisfied that the ferrite coil is correctly positioned, secure it firmly using hot glue. Small adjustments can be made afterwards by moving the wires that connect the ferrite coil to the PCB, before also securing these with more hot glue.

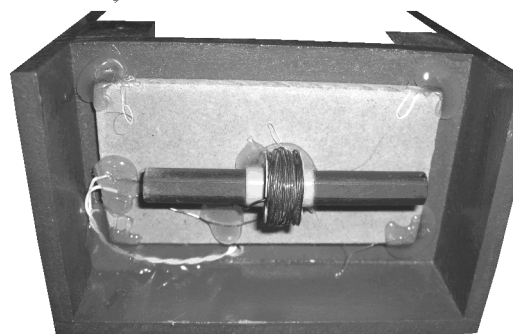

Fig. 12: Ferrite coil in enclosure

But Does it Actually Work?

This of course depends on your definition of "work." It is clear that the electronics in our PD actually do something, unlike many so-called LRLs which are filled with nonsense do-nothing electronics to fool the technically challenged. These scam devices often have no power supply, and rely on some highly dubious pseudo-scientific theory to explain their method of operation. In most cases, these LRLs are nothing more than dowsing rods dressed up in fancy clothing.

Does it work as a metal detector? At least in the active mode at short range, the answer is yes. When used in the active medium range mode there are definitely signals being detected, and you can even occasionally appear to be following a "signal line." In the passive long range mode the same can be said to be true, and it certainly acts as a very sensitive electromagnetic field detector.

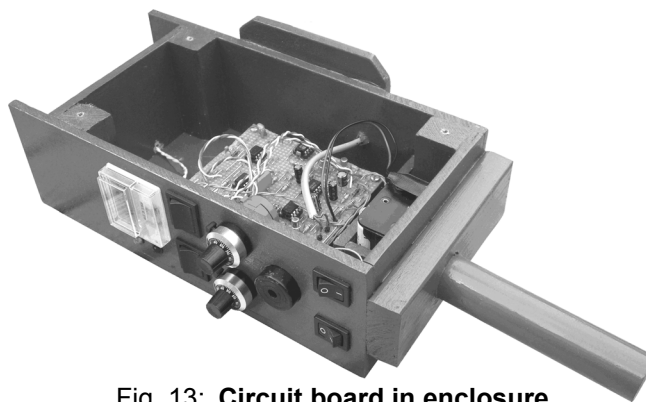

Fig. 13: Circuit board in enclosure

But does it detect treasure (in particular, gold) at long or even medium distances? Well, this is the big question. From the skeptical point of view the answer is almost certainly no, but as we stated at the start of this chapter, this project is highly experimental, and the intention was to keep an open mind during the development of this device.

According to LRL proponents, longtime buried targets are surrounded by a "phenomenon" that can be stimulated by a suitable transmitter operating in the frequency range between 60-70 kHz. How this is actually supposed to work is somewhat vague, and such a "phenomenon" is completely



Fig. 14: The completed TOTeM PD

unknown according to accepted science.

From a skeptical point of view the most likely explanation is that LRLs function by a combination of wishful thinking, self-deception and selective memory. When using the passive long range mode it is possible to imagine you are following a “signal line.” This could be due to many things, including multipath interference. Eventually you reach an area where the “signal line” appears to vanish or become erratic. LRL proponents attribute this to being close to the target, and at this point a conventional metal detector is employed to pinpoint the treasure. Usually something is located and recovered in the area, but the glory goes to the LRL for having detected it from several meters away. The very existence of the conventional metal detector being conveniently forgotten. Sometimes nothing is discovered, and this is where selective memory plays a role. Alternatively,

you can always conclude that the target must be too deep to find with the metal detector, or there is some elusive micro-gold that is causing an erroneous signal.

The purpose of this project was to develop a “working” experimental platform for anyone wishing to investigate this grey area of metal detecting. This is a highly speculative area of research, and there is absolutely no guarantee of success. Remember... here there be dragons!

Meaning of TOTeM

At the very start of this chapter it states “The TOTeM Project”, but what is the meaning?

Is it?

1. Because you can see a long way from the top of a totem pole? (ie. A tenuous reference to long range locating.)
2. An abbreviation of Totally Electromagnetic?
3. Or simply a “Trick Of The Mind”?

Whatever you believe, have fun building and experimenting with this device. Full construction details can be found in the remainder of this chapter, including a stripboard layout.

Construction Details

The component placement and layout are for illustrative purposes only. You may need to adjust the layout to accommodate components available in your area. In particular, please note that transistor pinouts can vary depending on the country of manufacture, even for what appears to be an identical part number.

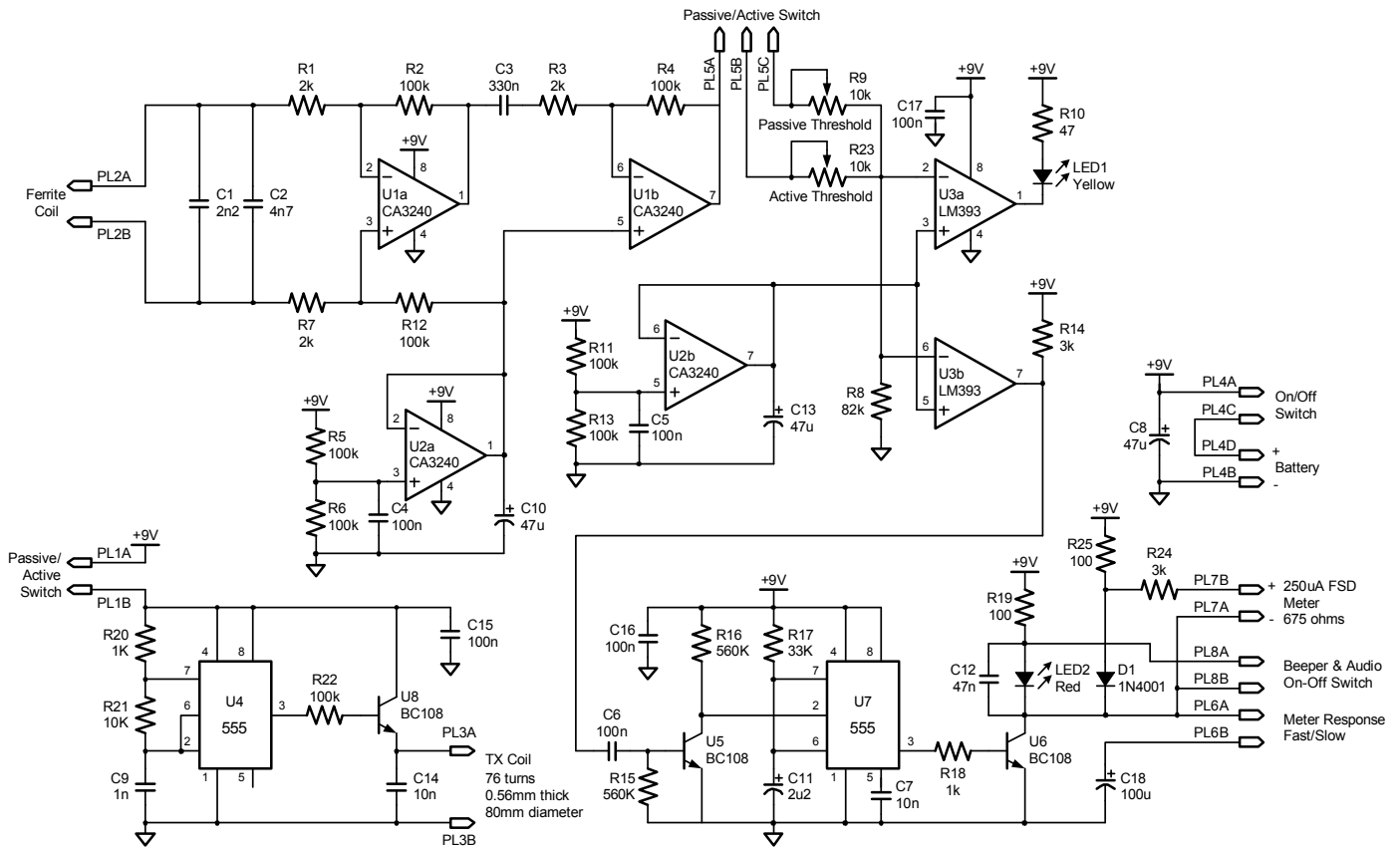

Fig. 15: Final TOTeM schematic

Due to the experimental nature of this project, a decision was made to use stripboard for the layout, rather than a PCB. There is unfortunately a lot of track cutting and jumpers required, but at least you will not need to resort to using nasty chemicals.

Note the connectors are designated as follows:

- PL1 = Passive / Active switch (TX power)
- PL2 = Ferrite coil
- PL3 = TX coil
- PL4 = Battery and on-off switch
- PL5 = Passive / Active switch (Threshold controls)
- PL6 = Meter response
- PL7 = Meter
- PL8 = Buzzer and audio on-off switch

However, in the prototype there were no connectors used. The wiring was soldered directly to the PCB.

Parts List

Resistors: (5% 1/4W)

R1, R3, R7	2k
R2, R4, R5, R6, R11, R12 R13, R22	100k
R8	82k
R9, R23	10k pot (10-turn)
R10	47
R14, R24	3k
R15, R16	560k
R17	33k
R18, R20	1k
R19, R25	100
R21	10k

Capacitors:

C1	2n2
C2	4n7
C3	330n
C4, C5, C6, C15, C16, C17	100n
C7, C14	10n
C8, C10, C13	47u elect., 6v3
C9	1n
C11	2u2 elect., 10v
C12	47n
C18	100u elect., 10v

Inductors:

L1	TX coil
L2	Ferrite coil

Diodes:

D1	1N4148
LED1	Yellow LED (with holder)
LED2	Red LED (with holder)

Transistors:

U5, U6, U8	BC108
------------	-------

ICs:

U1, U2	CA3240
U3	LM393
U4, U7	LM555

Switches:

S1	SPST (Power On-Off)
S2	SPST (Audio On-Off)

S3	DPDT (Active / Passive)
S4	SPST (Meter Response)

Misc:

- (5) 8-pin IC sockets
- Piezo-electric buzzer
- Control knobs 10-turn precision
- Battery holder to hold 6x AA alkaline batteries
- Meter 250uA (full scale) 675 ohms

Component Placement

The actual size of the stripboard is 4.0" x 3.0" (10.2cm x 7.6cm). PCB software was used to design the layout, with components placed on a 0.1" grid to suit the stripboard used in this project. See Figure 19. The jumpers on the top side were drawn as tracks. Some of the components (in particular, the transistors and certain electrolytic capacitors) did not have a footprint that would align correctly to the grid. In these cases the components may appear to be slightly off grid, requiring a small copper stub in the layout. These should be relatively easy to spot, but please be aware when placing components. U6 is a typical example.

Cutting the Tracks

There are a number of breaks required in the stripboard tracks, as shown in Figure 20. You can either use a special tool designed for the job, known as a spot face cutter, or a hand drill with a suitable sized bit. Be very careful to cut the tracks in the correct place without leaving any bridges across the break. It would be advisable to double-check with an eye glass. Likewise with the jumpers. If you get any of these in the wrong place it could prove very difficult to find the cause of the problem.

The copper tracks run horizontally across the board, and the triangles indicate the positions where breaks are required. The view is from the underside of the board for convenience.

The diagram in Figure 21 shows the copper side of the board overlaid with the breaks shown previously. This will assist with correct positioning of the components. Again, the board is viewed from the underside.

The 3-dimensional view (Figure 22) provides an idea of what the final product will look like in real life, except the two presets in the top right, which are replaced by multi-turn pots on the control panel.

Populating the Board

In order to minimise errors and mistakes during construction, please follow these instructions:

1. Make the breaks in the copper tracks on the bottom of the board.
2. Fit the IC sockets, which will act as a visual guide for the other components.
3. Add the wire links on the top of the board.
4. Use a continuity tester to check there are no unintentional shorts.
5. Build the transmitter and test this is working as expected when connected to the TX coil.
6. Insert the components in the pre-amp stage and the phantom ground circuit, and test for correct operation using an oscilloscope.

7. Fit the rest of the components.
8. Connect the board to the control panel, and test the comparators and audio stage.
9. Install and null the ferrite coil as described in previously in this chapter.
10. Perform the laboratory-based tests (spark detection, TV emission and MBN).

Control Panel Wiring Details

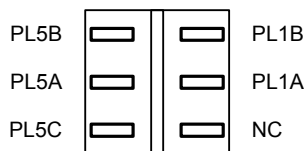

Fig. 16: Passive / Active switch wiring

The switch view is from the rear. Switch down = active, and switch up = passive.

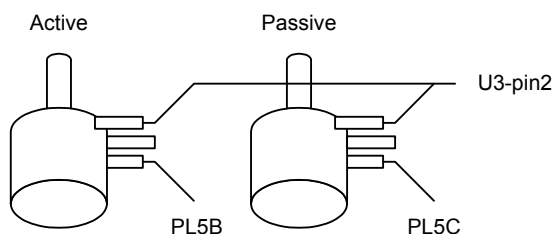

Fig. 17: Threshold pot wiring

The external Active and Passive threshold pots are wired in place of the presets shown on the circuit board layout. One important point to note is that the multi-turn pots have the center pin located at one end, and not in the middle like a standard pot.

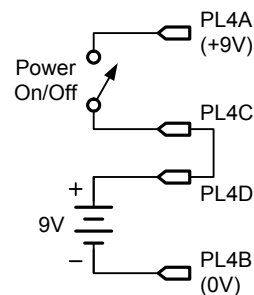

Fig. 18: Power switch & battery wiring

Conclusion

Unlike the original PD, the TOTeM project is easily replicated with a little care and attention. It easily passes all the laboratory-based tests used by LRL experimenters, and certainly appears to react in the same way as the device shown in the internet videos. Whether it will lead you to treasure or not is maybe another story, but at least you will have the opportunity to explore the pseudo-scientific world of long range locators for yourself, and make up your own mind on the matter.

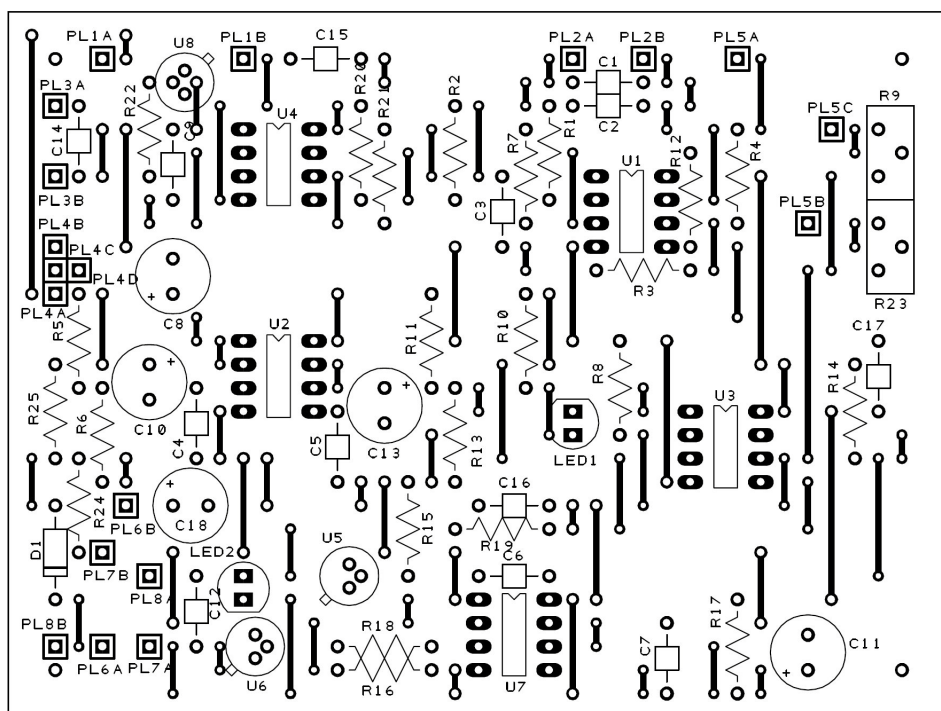

Fig. 19: Stripboard parts placement

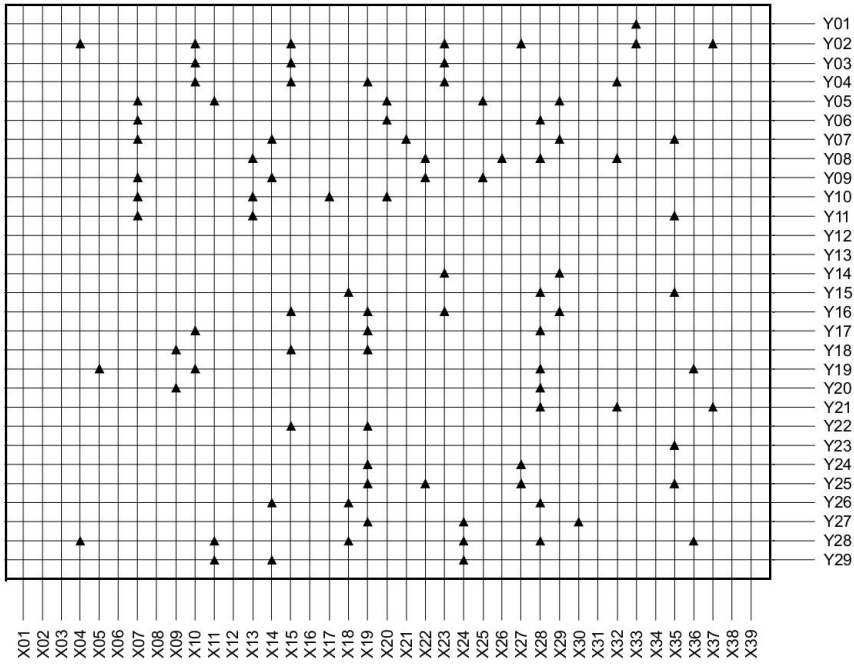

Fig. 20: Cut positions

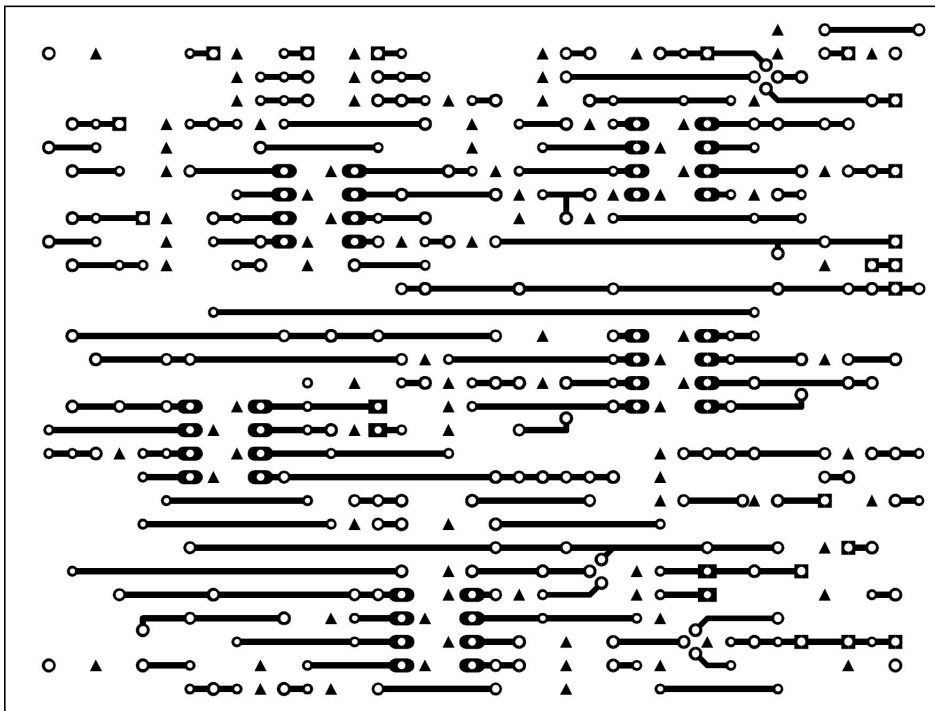

Fig. 21: Underside view with cuts

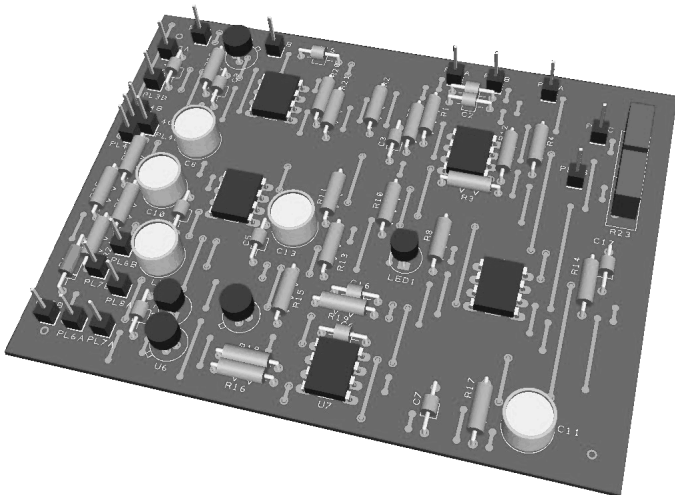

Fig. 22: Final 3D view